

---

**RMX16**

**Digital Reverberation System**

**User Manual**

## CONTENTS

---

<b>1 The Basic Principles of Reverberation</b>	
1.1 Introduction	4
1.2 Understanding Reverberation	4
<b>2 The RMX16 Digital Reverberation System</b>	
2.1 System Overview	6
<b>3 Operating Instructions</b>	
3.1 Introduction	9
3.2 Installation	10
3.3 Operation	11
3.4 Using the RMX16	15
<b>4 Theory of Operation</b>	
4.1 Introduction	17
4.2 Overall functional description	17
<b>5 Maintenance</b>	
5.1 Introduction	19
5.2 Service Information	19
5.3 General Maintenance	19
5.4 Troubleshooting	20
<b>6 Specifications</b>	
6.1 Electrical	23
6.2 Physical Dimensions	25
6.3 Options	25

---

<b>7 Warranty</b>	
7.1 Limited Liability	26
7.2 What to do if a fault is found	27
7.3 Shipping Information	27
7.4 Claim for damage during transit	27
7.5 Applications problems	27
<b>8 Quality Assurance</b>	28
<b>APPENDICES</b>	
APPENDIX A: BOARD EDGE CONNECTOR DETAILS	29
APPENDIX B: PRESET PROGRAM DESCRIPTIONS	30
APPENDIX C: HIGH AND LOW FREQUENCY DECAY CHARACTERISTICS	34
APPENDIX D: REMOTE OPERATING INSTRUCTIONS	35
APPENDIX E: BAR CODE WAND INSTRUCTIONS	40

## 1 The Basic Principles of Reverberation

---

### 1.1 Introduction

---

This section of the manual outlines the universal principles of reverberation.

### 1.2 Understanding Reverberation

---

The acoustic phenomenon known as reverberation accompanies nearly all of the sounds we hear, in fact we are so conditioned to hearing the accompanying reverberant field that on hearing sound totally lacking in reverberation (in anechoic chambers, well damped studios, etc.) we are immediately struck by its unnatural character.

Natural reverberation not only adds a certain amount of character, or colouration, to the actual sound it is accompanying, but also 'tells' our ears from which direction the sound is coming; approximately how far away the sound is; how loud the initial sound was; what type of acoustic space we are in; how large the space is; what the boundaries are like (hard walls, curtained walls, etc.) and so on.

'Dead Room' acoustics, approaching anechoic proportions, are found more and more in modern studio designs and because of the resulting lack of natural reverberation, a good reverberation system has been found to be mandatory in modern recording studios. 'Good reverberation' is not enough however, since the studio must be capable of reproducing all types of reverberant situations from 'sitting rooms' to 'great halls'. Only modern digital systems with carefully designed programs and large memory capacity, such as the RMX16, are capable of producing such a wide variety.

#### The Fundamentals of Reverberation

Let us say you are in the centre of a small hall and someone, standing a few feet away, claps their hands. Immediately the resulting sound wave will radiate in all directions at an approximate rate of one foot every millisecond. The first sound you will hear will be that which comes directly towards you from the clapped hands. Thanks to our well developed binaural hearing this 'Direct Sound' will tell us where the sound source is.

Next come the 'early reflections': remember sound was radiated in all directions and some of this radiated energy, on striking room boundaries (walls, floors, ceilings, etc.), will again be directed towards your ears. These early reflections may be slightly different in character from the original sound since not only is some of the energy absorbed by the boundary upon which the wave strikes, but this absorption also varies depending on the frequency.

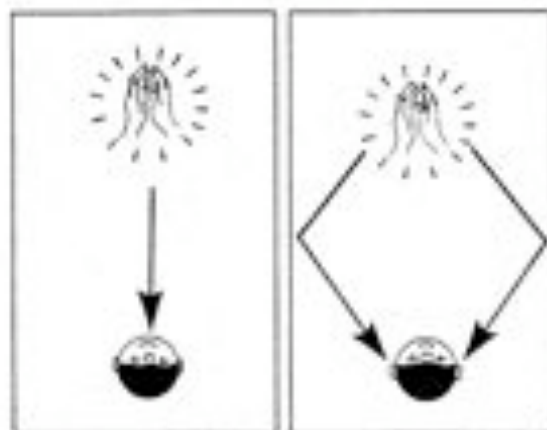

These early reflections can extend from 5ms in a small room to some 200ms in a large hall. Even at 200ms, if the sound is not impulsive, we are unable to pick out individual reflections during this period, but we are able to extract important psychoacoustic information about the type of hall and the type of boundaries involved.



These reflections eventually build up into an extremely dense, omni-directional reflection pattern called the 'reverberant period'. At this stage so many reflections are arriving at once that a pleasing diffuse sound is heard which slowly dies away.

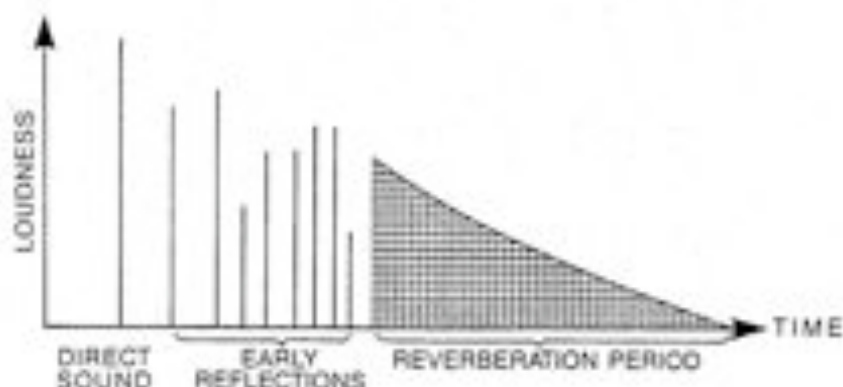

#### Stereo From a Mono Source

Another important aspect of sound in any acoustic space is its binaural nature. Sound occurs in three dimensional space and even a single hand clap is heard in stereo, even though emanating from a single source. The stereo image is created by each ear receiving a slightly different pattern of reflections, coming from different directions at different times. The 'stereo image' in artificial reverberation is an extremely important concept and should not be ignored. We never hear truly mono sounds in nature.

## 2 The RMX16 Digital Reverberation System

---

### 2.1 System Overview

---

The RMX16 digital reverberation system is totally electronic; the sound is completely unaffected by external vibrations or mechanical shocks. Unlike its mechanical counterpart the RMX16 system does not require special installation. This, together with the large reduction in size, the superior signal to noise performance and the greater bandwidth, gives the RMX16 significant advantages over old-fashioned mechanical reverberation systems.

With digital reverberation one can simulate mathematically any real environment and also any 'old fashioned' artificial reverberant character such as 'plates', or 'springs'. Digital reverberation techniques are the first to offer such sophistication.

The RMX16 digital reverberation system employs sophisticated micro-programmed parallel processing of 16 bit data offering an 18KHz bandwidth; 90dB dynamic range and 0.03 % distortion in delay mode; low power consumption (and therefore cool running); independent control of each program's fundamental reverberant parameters; alphanumeric program descriptions for ease of use and 'at a glance' understanding of how the unit is currently programmed as all data, including the variables (pre-delay, decay time, high frequency decay profile and low frequency decay profile), are continuously displayed on the reverb front panel.

The systems are designed to be simple to operate with nine factory programs simulating different reverberant environments with the ability to control all parameters. Nine user definable settings may be stored within the mainframe and a further ninety within the remote terminal. The user definable settings may be as complex as required. All reverberation parameters whether factory preset programs or user definable settings, are stored in non-volatile RAM and remain intact on power down.

The nine standard programs are stored in Erasible Programmable Read Only Memory (EPROM) and can only be altered by physical replacement of these devices. However, additional program storage (Softprogs 10 to 12 on the Mainframe and Softprogs 31 to 33 on the Remote Terminal) is available in the Random Access Memory (RAM) area which can be re-programmed with the use of the Remote Terminal and Bar Code Wand combined option (see appendices D and E for further details).

The unit can also be used as a very high quality, 18KHz bandwidth digital delay line. The delay can be varied from 0 to 1.6s in 1ms increments.

A calculator styled keypad is provided for entry of user definable variables and for storing or recalling information from the unit's memory locations.

Both input and output levels are adjustable to accommodate units sending or requiring non-standard signal levels. Overflow indication on digital processing is provided as well as the standard 'traffic signal' LEDs enabling fine adjustment of input level for optimum signal to noise performance.

When changing basic reverberation programs, the output is muted so that 'memory flush-out' is not output to the audio chain. If the basic program remains the same but the user has stored

a number of differing variables in various memory locations, then real time switching from one reverb setting to another can be accomplished.

A useful feature incorporated into the RMX16 reverberation system is the use of 'Nudge Buttons'. These buttons increment or decrement data for all selectable functions.

Many new digital reverberation systems offer either rack mounting mainframe units with no facility for remote operation, or hand held remote units with rack mounting mainframes but with no facility for control from the mainframe. The RMX16 system may be driven from the Mainframe or from a Remote Terminal which may be used 'hand held' or fitted into the mixing console.

This 'Remote' is a hand held terminal that connects with the mainframe via the standard cable or a stereo jack-field if required; the path, however, must not contain a transformer. All functions on the Mainframe are available on the Remote and the display of variable parameters will be echoed on the Remote's liquid crystal display. Ninety non-volatile memory locations for these parameters are available when using this terminal. So with the use of the Remote Terminal not only are the fundamental programs retained on power-down, but up to ninety nine personal reverberation patterns may be stored without loss.

A Remote once programmed with ninety memories may be removed and interfaced to any other AMS reverberation system. All AMS reverberation systems are compatible and thus once a sound has been found and the parameters stored within the unit it may be regenerated on any RMX16 system anywhere in the world.

The Remote Terminal option, if purchased in combination with the Bar Code Wand Option, not only provides simple effective remote operation, but also increases the power of the RMX16 to store programs. With the purchase of this option three 'Soft Program' stores on the mainframe and four 'Soft Program' stores within the remote are immediately available. These 'Softprog' stores must not be confused with the parameter stores described earlier and already available on the remote; they are much more powerful. The 'parameter' stores only contain user settings of already existing programs. The 'Softprog' stores contain actual programs, each of which can be manipulated, transferred from remote to mainframe and from mainframe to remote.

The 'Softprogs' are issued as bar coded sheets that are contained within a bar code booklet. A number of bar coded programs are included in the price of this option. Further issues of the bar coded programs are supplied at a nominal charge. In this way eventually a complete library of unique programs can be assembled, any one of which may be loaded into the Remote or the Mainframe as desired.

Both the Remote and the Mainframe are engineered to the same high standard as the rest of Advanced Music Systems' equipment and both offer microprocessor controlled programmability, repeatability and storage capability putting the engineer in complete control of every system function. Control of reverberation programs and parameters is contained in EPROM, thereby guaranteeing that the hardware will not become outdated as advances in reverberation techniques occur.

The RMX16 is designed as a rack mounting unit 3.5" / 2U high and 13" deep, excluding knobs and connectors. A flight case is available as an option if required. The choice of components

and quality of construction are of a very high standard and because of the choice of a mother board system with plug in circuit cards and ribbon cables, maintenance problems are reduced to a minimum.

Perhaps one of the most important aspects of the RMX16 Digital Reverberation System is its ability to withstand the push to obsolescence. The unit is designed for maximum hardware / software flexibility, with a maximum of software control, thus enabling it to be easily upgraded as new developments take place.

There is no doubt that the unit's small size and rugged construction, coupled with unquestionable performance characteristics, represent the best value in reverberation technology available in the world today.

## 3 Operating Instructions

---

### 3.1 Introduction

---

This section of the manual contains information regarding installation and operation of the RMX16 Stereo Reverberation System. It is recommended that the contents of this section are read and understood before attempting to operate the unit (try our way first!). Should any difficulties arise during operation contact your nearest AMS representative, or contact:

#### ADVANCED MUSIC SYSTEMS

AMS Industries plc  
AMS Industries Park  
Billington Road  
BURNLEY  
LANCASHIRE  
BB11 5ES  
ENGLAND

OR TELEPHONE: 0282 57011 / TELEX: 63108 AMS-G / FAX: 0282 39542

### 3.2 Installation

---

3.2.1 The model RMX16 can be operated with a line input voltage of 110, 220 or 240 Volts, adjustable externally. Before connecting the equipment to primary power check that the line voltage setting is correct (see the voltage setting on the back of the unit); if it is found that the line voltage setting is incorrect use the following procedure to change it:

[a] Disconnect the line power cord from the unit.

[b] Insert a small screwdriver into the slot at the top of the mains cover flap and lever the flap open.

[c] Dropping the flap will give access to both the voltage selection barrel and the mains fuse.

[d] The voltage selection barrel should then be removed and replaced so that the correct voltage setting is facing.

[e] Once the correct setting has been programmed the flap should be replaced.

[f] The line power cord may now be replaced.

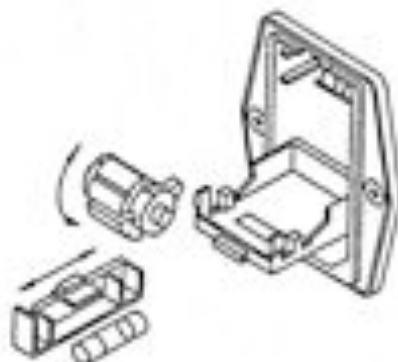

**3.2.2** The outputs of the RMX16 are balanced electronically but are compensating. This ensures normal operation if an unbalanced line is connected to the unit.

**3.2.3** The connections to the rear of the unit are as follows:

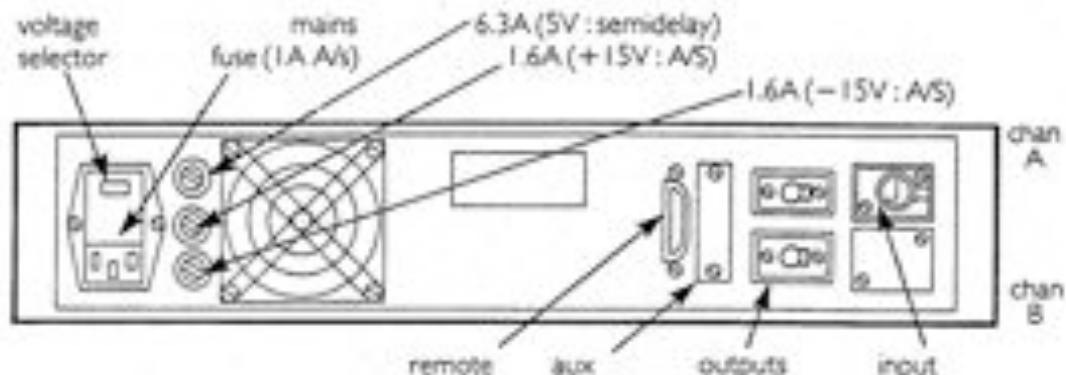

### 3.2.4 MAINS WIRING

All mains leads supplied with equipment manufactured at AMS are wired in accordance with the European (I.E.C.) colour code. The code is as follows:

BROWN	- LIVE
BLUE	- NEUTRAL
GREEN/YELLOW	- EARTH

### 3.2.5 FUSE REPLACEMENT

All power supply rails within the RMX16 reverberation system are protected by current limiting and protected against overvoltage. If for any reason the voltage on a particular rail exceeds certain limits, a thyristor connected across the respective power rail is activated, thereby blowing the fuse and protecting the unit's electronics. It should be noted that this may (very occasionally) happen when no fault is present, but when a sharp and possibly dangerous mains surge has occurred. There are four fuses contained within the RMX16 reverberation unit. The mains fuse is contained behind the flap of the mains voltage selector compartment. Details of access to this compartment and the exact placement of the fuse are given in part 3.3.1 above. All of the other fuses are immediately accessible on the rear panel of the RMX16. If supply rail failure occurs, the appropriate LED will extinguish. The supply rail test points are shown overleaf.

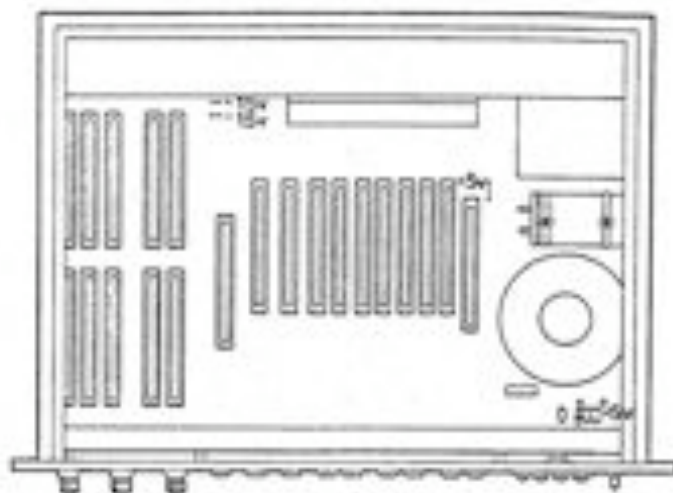

### 3.3 Operation

#### 3.3.1 GENERAL INTRODUCTION

This section is intended to familiarise the user with the front panel controls of the RMX16 reverberation system. Frequent reference to the front panel drawing on the fold-out page at the back of the manual is therefore recommended when following this section.

#### 3.3.2 INPUT / OUTPUT LEVEL AND LEVEL MONITORING SECTION

When the unit is switched on, the front panel LEDs will illuminate. Between the Input level and Output level control knobs there are four LEDs (green, yellow, red and red). The first three (i.e. green, yellow and red) are basic 'traffic signal' level LEDs. The red LED is illuminated 6 dB, the yellow LED 12 dB and the green LED 18 dB before clipping. In normal operation, with a signal present, the input level should be adjusted so that the red LED is illuminated only when the highest programme peaks occur. The remaining red LED indicates processing overflow. Should this occur, due to exceptional program material, 'backing off' the input level slightly will prevent internal clipping of the signal.

Once the input signal has been 'level matched' using the traffic signal LEDs, the output (stereo) can be adjusted to give a good match on the mixing desk.

The output from the RMX16 is true stereo and while these outputs may be used singly, a more solid spatial sound will be obtained by using the stereo pair.

#### 3.3.3 THE POT CONTROL SECTION

Depressing the *pot* key hands control of decay time over to the rotary control knob above the actual pot key. This facility can only be used once the decay time function has been selected.

### 3.3.4 PROGRAM SELECTION

To select one of the reverberation programs first push the 'program' key, the LED on this key will now illuminate. Actual program selection can be accomplished in two distinct ways:

#### (A) KEYPAD ENTRY:

To select a reverberation program using the keypad, enter a single digit number between 1 and 9 followed immediately by the 'enter' key (#); the required program will then be loaded down into the temporary store location. Once a program number has been selected the LED on the 'program' key will flash until the 'enter' key (#) is pressed. If the program number selected is not available (eg. greater than 12), then the error message (E) will be displayed above the 'program' key. No change in program will result and therefore the program LED will still flash. Re-pressing of the 'program' key will clear the error condition from the display.

#### (B) USING THE NUDGE KEYS:

The 'nudge' keys are very useful for jumping from one program to another. Once 'program' has been selected, a nudge up will increase the program number while a nudge down will decrease the program number.

It should be noted that when changing between basic programs, the output is muted for a short period so that 'memory flush-out' is not output to the audio chain.

This does not happen when changing from the basic program to a user variation of that same program. With this type of change, real time program jumping can be accomplished.

### 3.3.5 PRE-DELAY ENTRY

Pre-delay delays the onset of reverberation giving the impression of distance from the sound source. To introduce a pre-delay before reverberation occurs, first push the 'predelay' key. The LED on this key will now illuminate. Again, actual predelay setting can be accomplished in two distinct ways:

#### (A) KEYPAD ENTRY:

Using the keypad, enter the amount of pre-delay required. The amount (ms) of pre-delay will be displayed above the 'predelay' key and as information is entered from the keypad the LED on the 'predelay' key will flash. If the requested pre-delay time is within certain limits, the output will be delayed with respect to the input by this amount and the LED will stop flashing. If the requested pre-delay time is greater than that which is available using the program selected, the error message (E) will be displayed above the 'predelay' key. No change in the program will result so the 'predelay' LED will continue flashing. To clear this error the predelay key should be pressed again.

#### *(B) USING THE NUDGE KEYS:*

If the Nudge Keys are used, the pre-delay amount will be increased or decreased; the step size being program dependent.

It is important to remember that the maximum available pre-delay time depends on the basic reverberation program in use. The maximum pre-delay time for each reverberation program is given in the program notes at the back of this manual (see APPENDIX B).

### **3.3.6 DECAY TIME ENTRY**

To vary the decay time first push the 'decay time' key. The LED on that key will now illuminate. There are three ways of adjusting decay time:

#### *(A) KEYPAD ENTRY:*

Decay time may be selected using the keypad. Both the minimum and the maximum decay times are dependent upon the program selected. Fractions of a second are entered by using the '\*' key as a decimal point. Hence 2.8 Seconds would be entered by first pressing the 'decay time' key followed by the '2' key, the '.' key, the '8' key and finally the enter key (#).

#### *(B) USING THE NUDGE KEYS:*

Once the 'decay time' key has been pressed, an increase or decrease in the decay time can be accomplished by the use of the nudge keys. Depressing the nudge up key will result in the illumination of the nudge up LED and an increase in the decay time. Depressing the nudge down key will result in illumination of the nudge down LED and a corresponding decrease in the decay time. The decay time will increase or decrease in 0.1 second steps.

#### *(C) POT CONTROL ENTRY:*

To vary the decay time using the pot control, simply press the pot key. Once the decay time function has been selected, control of the decay time is immediately surrendered to the rotary pot directly above the pot key.

### **3.3.7 DECAY FILTER CONTROLS**

The availability and use of these controls is dependent upon the basic reverberation program in use (See Appendix B).

For example PROGRAM 1 allows use of both the high and low filter controls while PROGRAM 3 allows for use of the high filter control only.

A positive filter setting will produce an increase in reverberation time in the selected frequency band while a negative value will give a decrease. A low frequency filter setting of, say +9, will give a large increase in reverberation time in the low frequency band.

To select negative values the "\*" key must be pressed prior to entering the numeral. If the "\*" key is not pressed a positive value is assumed.

The decay filter controls may be changed by using the nudge buttons.

### 3.3.8 DATA STORAGE

The basic structure of each program is such that it will simulate the environment it is designed to replicate; for this reason it is fixed. However, as seen above, extensive control of parameters within the basic framework is possible. When a program is 'called' the control parameters are entered into a temporary store (the letter 'Y' is displayed in place of the program number or store location), the output and display reflecting the contents of the temporary store and not the preset program. The temporary store (T) is non-volatile and therefore data in this location, like all other store locations, is not lost on power down.

There are nine non-volatile user setting store locations incorporated in the mainframe of the RMX16 reverberation unit.

To transfer a set of parameters from the temporary store to a user settings store location, press the 'save' key, at this point the LED on the 'save' key will flash and the store control digit in the display will reflect the last store location accessed. If this is the required store location then continue as indicated otherwise enter a number between 1 and 9 (other than the one displayed) and press the enter key (#). The 'save' LED will now be extinguished and the temporary store location (T) will reflect the stored data. Alterations to the displayed data will not affect the stored data but illustrate changes affecting the temporary store.

To recall a store location that has been previously set up, simply press the recall key followed by the store location number and then press the enter key (#).

As mentioned previously, if a jump between pre-set programs is requested the output is temporarily muted to ensure that 'memory flush-out' is not sent to the audio chain. If, however, a jump between differing parameters is requested (using the same basic pre-set program) then no such muting will take place, thus allowing real time switching between completely different user settings.

### 3.3.9 THE NUDGE KEYS

The Nudge Keys, as described earlier, provide a quick and convenient method of changing variables. If a nudge key is pressed and held down during nudging, the parameter will change by the nudge rate. If the key is pressed and released in quick succession then the basic nudge rate can be exceeded.

### 3.3.10 THE KEYPAD

Keypad data entry is provided for entering variable data and for storing programs. This type of data entry is precise and repeatable giving the engineer accurate control over program functions.

The A, B, C and D keys have been reserved for special control of programs and their functions are program dependent. For example, the ECHO program uses A and B to select the output to be programmed. This information is contained in the program descriptions of Appendix B.

### 3.3.11 POWER SWITCHING

Switching the power 'off' in this case does not mean a loss of program details. Not only are the pre-set programs non-volatile, but all memory locations are also non-volatile. This means that nine personal settings may be stored in the mainframe together with the temporary settings and none of these will be lost when the unit is switched off. When the unit is switched on again, the set up of programs and parameters will be exactly the same as at power off. The 'softprog' stores may be initialised (cleared) on switch on by holding down the T key on the numeric keypad while switching the unit on.

## 3.4 Using the RMX16

---

Once the unit has been correctly 'level matched' decide which basic program is needed for the effect you require. Reading through the program list in APPENDIX B will help if you are already familiar with basic reverberation sounds. If you are not it is advisable to listen to all of the basic pre-set programs using the material you wish to record as the source. You will then be able to select the basic program nearest to the effect you require.

Do not use source material with a fundamentally different frequency character than the material you will eventually record, this will give you a false impression of the final sound. Almost all reverberation types, especially when using large amounts of frequency contouring, are dependent upon the frequency character of the source material.

Press the 'program' key and nudge up or down through the programs to the one required. The program number appears on the left of the display, the program name on the right. Whether nudging up or down, the output will be muted for a short time. Mute time is not compounded i.e. is the same regardless of how many programs are nudged through and which program you are nudging to or from. There are nine factory pre-set programs; choose the one you wish to use and refer to the program notes at the back of this manual (APPENDIX B). These notes give the maximum pre-delay, the maximum decay time and the decay filter ranges available when using each particular program.

### PRE-DELAY

Pre-delay offsets the output of the RMX16 relative to the input. When mixing the original with the output of the reverberation system a variety of material can be enhanced by adding pre-delay; knowing when to use pre-delay and how much to use comes with experience.

### DECAY TIME

Increasing decay time effectively increases the length of the final phase of reverberation i.e. the reverberant period. By using the 'pot' control the decay time may be varied at any time during a mix.

### DECAY FILTERING

The effectiveness of these controls depends to a large extent on the frequency character of the source material. The high frequency filter will have no effect at all on low range instruments like the bass guitar whereas cymbals, violins, etc., will be affected to a large degree; there is no substitute for experimentation.

### STORAGE

If you find a setting different from the basic pre-set program and would like to store this setting for recall at a later date you should read section 3.4.8 DATA STORAGE; this will describe the basic storage rules.

In section 3.4.8 reference is made to the possibility of real time switching between reverberation patterns during a mix. To accomplish this, first set up the two (or more) reverberation patterns required and store them; for example, store locations 1 and 2. REMEMBER you must only use one basic pre-set program to set both reverberation patterns. This will prevent audio muting when switching between stores. Now recall the initial reverberation pattern, for example 'STORE 1' and start the recording. Well before the moment that the program jump is required, press the 'recall' key followed by the '2' key (STORE 2); do not press the enter key (#) at this point. At the precise moment that the second program is required press the enter key (#).

## 4 Theory of Operation

---

### 4.1 Introduction

---

This section of the manual contains a description of how the RMX16 reverberation system works together with a functional block diagram of the unit overleaf.

### 4.2 Overall Functional Description

---

The balanced input to the RMX16 is processed into unbalanced form and fed through low pass filtering to prevent aliasing components appearing at the output of the reverberation system. The sampler card accepts this filtered signal which is fed to sample and hold circuitry and then to a comparator / gain switching section. At this point the signal is scaled by 1, 2, 4, or 8 to optimise the signal to noise ratio and a two bit exponent number is generated to note the scaling factor used. Control and timing are derived from the memory control boards, the clock inputs being generated by a crystal oscillator. When an analogue to digital conversion (ADC) command is decoded, the resulting response 'conversion complete' is used to control the latching of the correct exponent for that sampling period.

The sampled analogue output from the sampler card is fed into the ADC via a buffer amplifier. Timing signals from the sampler card cause a conversion to be initiated. The twelve bit result and the two bit range data are converted into linear sixteen-bit format and latched into a set of registers/data highway drivers for storage in memory.

**NOTE:** this form of encoding largely mimics the performance of the ear and does not suffer from noise breathing effects, etc.

This sixteen bit data is then manipulated by an array of arithmetic processors which are micro-programmed to perform the large number of multiplications, additions, divisions and subtractions required in each sampling period to generate high quality reverberation. In fact, the equivalent of over 1,000 delay taps, each with its associated amplitude weighting, is required per second to simulate an acceptable natural reverberation.

The 128K byte memory is used for audio delay generation and as scratchpad memory. Internal data word length in the 22MHz arithmetic processors is twenty eight bits. The two sixteen bit results from the arithmetic processor calculated as representing the stereo reverberation outputs are converted back to analogue form on the DAC (Digital to Analogue Converter) card. The two outputs from the DACs are buffered and filtered to remove any sampling steps and recover the high frequency information. After adjustment of amplitude by the output level control the signals are then fed through balanced compensating output stages to the output XLRs on the rear of the unit. Operator communication to and from the 'Executive processor' is accomplished via the display board which contains the drive for the display, together with the display itself.

RMX16 BLOCK DIAGRAM

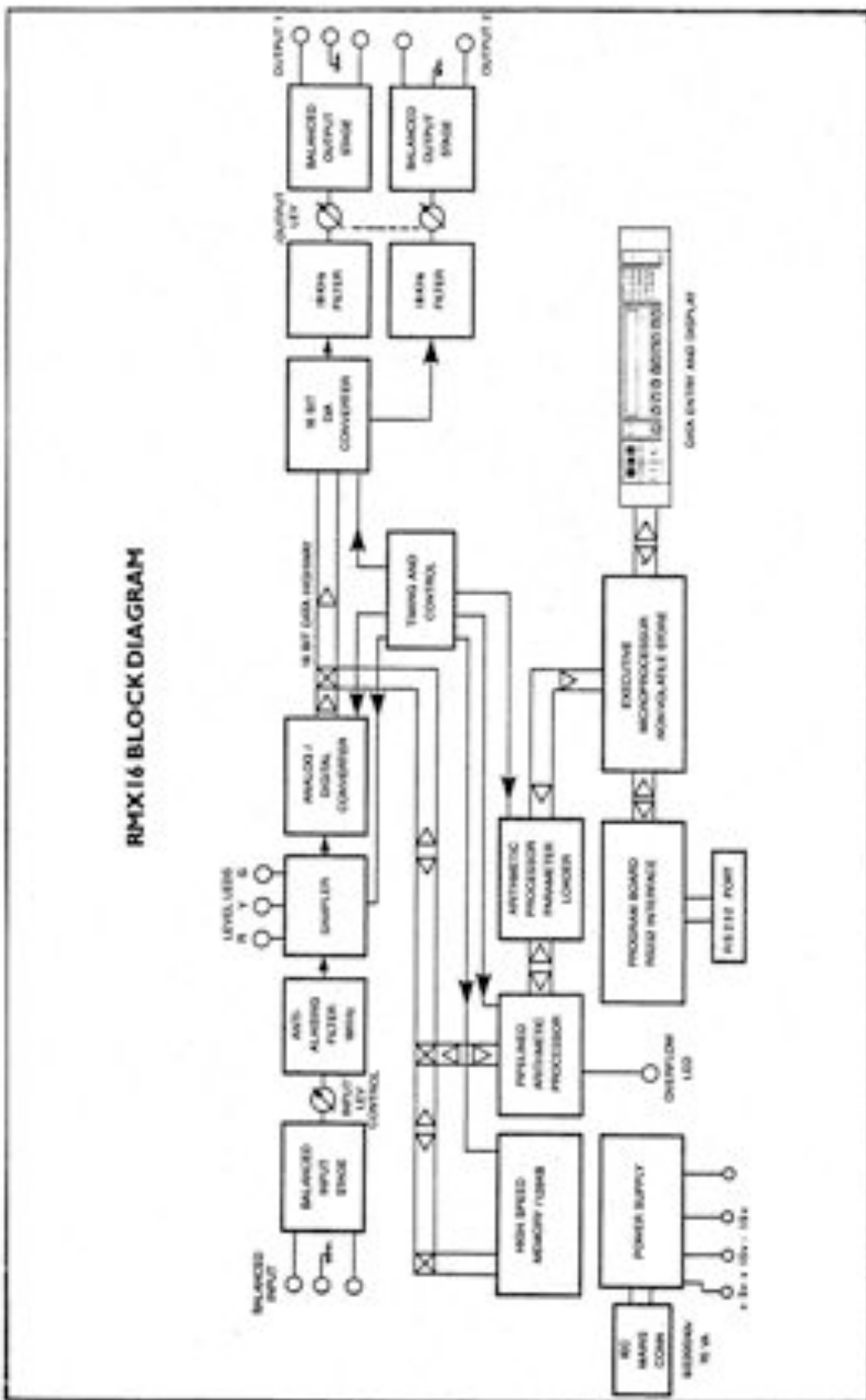

## 5 Maintenance

---

### 5.1 Introduction

---

This section contains maintenance information for the RMX16 and includes general maintenance procedures and trouble shooting information.

### 5.2 Service Information and Warranty

---

**5.2.1** Each RMX16 is warranted for a period of one year upon delivery to the original purchaser. Details of the warranty are given in Section 6 of this manual.

Should a fault occur, telephone or telex the AMS Service Department or your nearest AMS approved service facility. They will usually be able to diagnose the fault with information supplied over the telephone or telex so a quick repair can be achieved avoiding the need to send the unit back to the factory. This not only saves the cost of shipping, but also reduces the 'down time' of the unit. Most service repairs on our products can be accomplished by advanced replacement of parts, supplied with instructions for fitting, so that they can be installed easily by even the most unskilled personnel.

**5.2.2** A factory service is available for the RMX16 on request. Shipping information is given in Section 7.3 of this manual. If required, an estimate can be provided to the customer prior to work being carried out.

**5.2.3** Software updates are free of charge for a period of 12 months from date of purchase. Updates will not be automatically sent out. It is up to individual customers to check that their software is up to date prior to the expiration of the guarantee period.

### 5.3 General Maintenance

---

#### 5.3.1 ACCESS

All printed circuit board assemblies can be accessed by removing the top cover plate, five DZUS fasteners hold the plate in place. To loosen the DZUS fasteners a 90 degree anti-clockwise rotation is all that is required so that the slot runs from left to right. For cleaning purposes it will also be necessary to remove the bottom plate. The bottom plate is held on by four DZUS fasteners. The front panel is affixed by four M5 x 10mm countersunk socket head screws (black) and can be removed using a 3mm AF Allen key. The display board is held on to the front panel by nine M3 x 20mm countersunk socket head screws (black) together with nine 8mm spacers, washers, shake proof washers and nine M3 nuts; the display board should be removed by unfastening the nuts on the rear of the board. The fan and the fan guard are also held on by four M5 x 10mm Pan Head Posidriv screws.

### 5.3.2 CLEANING

The RMX16 should be cleaned periodically to remove dust, grease and other contaminants. The surface of all the printed circuit boards should be cleaned using dry air at low pressure (psi). If grease is to be removed use Arklone F or Freon TF and remove grime with clean dry air at low pressure. Clean the front panel with a soft cloth dampened with a mild solution of detergent and water. **DO NOT USE ARKLONE or FREON ON THE DISPLAY FILTER** as this will cause damage.

Only high quality, heavily gold-plated edge connector blades and edge socket pins are used and problems in this area are unlikely to occur. It is extremely important that chemical contact cleaners are not used on these blades. This type of cleaner results in gross contamination of the edge pin sockets that cannot be removed without replacing the socket itself. If you suspect problems in this area, then, as a last resort only, use a rubber to clean the edge blades in question.

### 5.4 Trouble Shooting

---

The following section has been written as a guide for fault finding in case of malfunction during service. If the RMX16 malfunctions while under warranty, contact the service department at AMS or an AMS distributor. If an attempt is made to service the unit whilst it is still under warranty without guidance or permission from one of the above bodies, warranty may well be invalidated.

Before embarking on the checking procedures outlined below, ensure that all the power supplies are at their correct potential (see drawing in section 3.3.5 for supply test points) and that all the fuses are intact; also check the input wiring external to the RMX16 for short circuits.

If either the + 15V or - 15V rail is faulty it is possible that the trouble is caused by one of the small Bead Tantalum Capacitors. To ascertain whether or not this is the case, pull each card out in turn (one at a time) to see whether the rail voltage returns to normal.

**CAUTION:** Plugging cards in and out and card exchanges should obviously only be done with the unit switched off. When removing or replacing cards please take great care in ensuring that the cards are replaced in the correct slot with the correct orientation as listed on page 22.

If a multiplier card is suspect, select program 5 (the delay program). In this program only the multiplier card in slot EC9 is actually utilised. Thus each multiplier may be plugged into this slot, in turn, to determine which of the boards (if any) is faulty.

Possible causes are listed overleaf in order of probability and therefore should be checked in strict order.

SYMPTOM	POSSIBLE CAUSE
Loss of output on one channel	1. Output short circuit: Check both the cable connected to the unit and the internal wiring of the unit for that channel 2. The DAC card
Loss of output on both channels with level LEDs also not working	1. Input short circuit: Check both the cable connected to the unit and the internal wiring of the unit 2. The input card 3. The sampler card
Loss of output on both channels with level LEDs operational	1. The ADC card 2. Both the memory control cards
Intermittent output on both channels	1. Faulty RAM card 2. Faulty memory control cards
Intermittent distortion on both channels	1. Faulty RAM card 2. Multiplier card
Constantly distorted output on both channels	1. Input card 2. Sampler card 3. ADC card 4. Multiplier card
Constantly distorted output on one channel	1. DAC card
Front panel LEDs not illuminated / incorrect parameters displayed	1. The processor card 2. The program interface card 3. The front panel board
Reverberation not in agreement with display parameters	1. Processor card 2. The program interface card 3. Memory control card - MCB (S)
All level LEDs lit including the overflow LED	1. -15V supply faulty 2. Sampler card
No LEDs lit at all on the front panel	1. +5V supply 2. +15V supply
Pot not working properly	1. Front panel board
Different output levels on all programs	1. Exponent control card 2. DAC

The list that follows indicates which board goes in which slot and the way the components face when the front panel is towards you.

SLOT	BOARD	DESCRIPTION	DIRECTION
EC1	DMX 1	INPUT CARD	RIGHT
EC2	DMX 15	SAMPLER CARD	RIGHT
EC3	DMX 14	ADC CARD	RIGHT
EC4	DMX 44	EXPONENT CONTROL CARD	RIGHT
EC5	DMX 20 or 77	DUAL DAC	RIGHT
EC6	DMX 32	MCB 5/A	LEFT
EC7	DMX 69	RAM CARD	LEFT
EC8	NOT USED!		
EC9	DMX 31	MULTIPLIER CARD(S)	LEFT
EC10	DMX 31	MULTIPLIER CARD(S)	LEFT
EC11	DMX 31	MULTIPLIER CARD(S)	LEFT
EC12	DMX 33	MCB 5/B	LEFT
EC13	NOT USED !		
EC14	DMX 43	PROGRAM INTERFACE CARD	LEFT
EC15	NOT USED !		
EC16	DMX 23	MICROPROCESSOR CARD	RIGHT

ECs 1 2 3 4 5 6 7 8 9 10 11 12 13 14 15 16

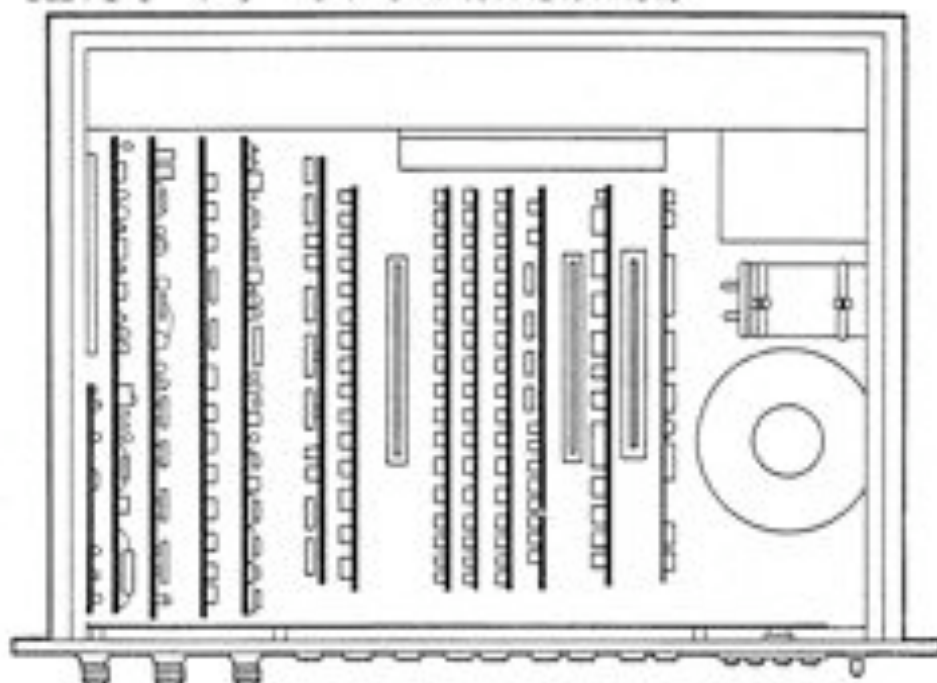

## 6 Specifications

---

### 6.1 Electrical

---

Input Impedance (Z <sub>in</sub> ):	10K ohm : Electronically balanced.
Input Sensitivity:	-10 dBV : Ref. 0.775 Volts.
Input:	One channel: 3 pin female XLR socket.
Output Impedance:	150 ohm : Compensating Electronically balanced.
Maximum Output Level:	+ 20dBV.
Outputs:	Two channel (Stereo): 3 pin male XLR sockets.
Distortion:	Less than 0.00% at 1 KHz, full output
Dynamic Range:	90dB.
Frequency Response:	20Hz to 18KHz : - 3dB , + 0dB.
S/N Ratio:	Dependent upon reverberation program selected but typically 86dB.
Power consumption:	70VA maximum.
Power requirements:	110/220/240 VAC : Externally ( 50/60Hz ) adjustable.
Power connector:	Standard IEC mains connector.
Preset program range:	9 individual programs supplied as standard.

#### Parameter storage:

9 parameter stores are available on the mainframe as standard. 90 parameter stores are available within the remote terminal as standard.

#### Soft Program Stores:

##### Standard fitting:

3 on mainframe-stores 10, 11 and 12; 4 within the remote-stores 31, 32, 33 and 34. Only useable in conjunction with the bar code wand and software booklet.

##### Optional fitting:

A further 18 'Softprog' stores are available if the 'Softprog card' is purchased.

**Nudge:**

Program: Will nudge through programs allowing quick selection of program required.

Predelay: Nudges from 0 to maximum in steps of 10 milliseconds.

Decay time: Nudges from 0 to maximum in 0.1 Second steps.

Decay filtering: Nudges up and down in single digitsteps.

**Computer Control:**

Program Entry: Keypad entry 1 to 9.

**Predelay Entry:**

Keypad entry 0 to maximum (dependent upon program selected); least significant digit = 1mS.

**Decay Time Entry:**

Keypad entry least significant digit = 0.1 Second. '\*' acts as decimal point.

**Filter settings:**

Keypad entr : signed single digit numeric. '\*' acts as minus sign. Positive value implied if digit not preceded by '\*'.

**Display:**

All parameters displayed. Display Comprises:11x7 Segment digital characters with 8x17 Segment starburst alphanumeric characters.

## 6.2 PHYSICAL DIMENSIONS

These units are designed for 19" rack mounting and have the following dimensions:

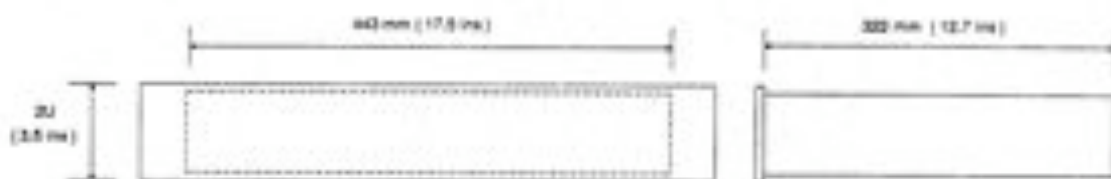

### CASE DIMENSIONS

Height:	2U (3.5")
Width:	443mm (17.5"); Behind front panel
Depth:	322mm (12.7"); Behind front panel
Weight:	12Kg (including packaging)

## 6.3 Options (see Appendices)

### (A) REMOTE TERMINAL:

The hand held remote terminal is powered by 4 NiCad cells which may be re-charged via the connecting cable from the RMX16. The terminal uses a three wire system for transmitting and receiving data and therefore may be connected via a stereo jack field using normal audio leads (so long as the path does not contain a transformer); the maximum length of signal path between the Remote Terminal and the RMX16 is 25 metres.

The battery back-up within the remote is trickle charged when used with the RMX16 (see separate manual for operating instructions).

### (B) BAR CODE WAND:

The RMX16 Remote Terminal has provision for the addition of a bar code reading pen. This allows immediate updating of reverb programs as new software becomes available. A bar code pen user will receive software in the form of bar codes on sheets of A4 paper. In this way, a library of reverb programs can be built up.

### (C) FLIGHT CASE:

A flight case is available as an option if required.

## 7 Warranty

---

### 7.1 Limited Liability

---

ADVANCED MUSIC SYSTEMS, HEREIN AFTER KNOWN AS THE MANUFACTURER, GUARANTEES THIS EQUIPMENT FROM DEFECTS IN MATERIAL AND WORKMANSHIP UNDER NORMAL USE AND SERVICE FOR A PERIOD OF ONE YEAR. THIS GUARANTEE EXTENDS TO THE ORIGINAL PURCHASER ONLY AND DOES NOT APPLY TO FUSES OR ANY PRODUCT OR PARTS SUBJECTED TO MISUSE, NEGLIGENCE, ACCIDENT OR ABNORMAL CONDITIONS OF OPERATION. THE GUARANTEE BEGINS ON THE DATE OF DELIVERY TO THE ACTUAL PURCHASER OR TO HIS AUTHORISED AGENT OR CARRIER.

IN THE EVENT OF FAILURE OF A PRODUCT COVERED BY THIS GUARANTEE, THE MANUFACTURER OR THEIR CERTIFIED REPRESENTATIVES WILL REPAIR AND CALIBRATE EQUIPMENT RETURNED PREPAID TO AN AUTHORISED SERVICE FACILITY WITHIN ONE YEAR OF THE ORIGINAL PURCHASE AND PROVIDED THAT THE GUARANTORS EXAMINATION DISCLOSES TO ITS SATISFACTION THAT THE PRODUCT WAS DEFECTIVE. EQUIPMENT UNDER THIS GUARANTEE WILL BE REPAIRED OR REPLACED WITHOUT CHARGE. ANY FAULT THAT HAS BEEN CAUSED BY MISUSE, NEGLIGENCE, ACCIDENT, ACT OF GOD, WAR OR CIVIL INSURRECTION; ALTERATION OR REPAIR BY UNAUTHORISED PERSONAL; OPERATION FROM AN INCORRECT POWER SOURCE OR ABNORMAL CONDITIONS OF OPERATION, WILL NOT FALL UNDER THIS GUARANTEE. HOWEVER, AN ESTIMATE OF THE COST OF THE REPAIR WORK WILL BE SUBMITTED BEFORE WORK IS STARTED.

THE MANUFACTURER SHALL NOT BE RESPONSIBLE FOR ANY LOSS OR DAMAGE, DIRECT OR CONSEQUENTIAL, RESULTING FROM MACHINE FAILURE OR THE INABILITY OF THE PRODUCT TO PERFORM.

THE MANUFACTURER SHALL NOT BE RESPONSIBLE FOR ANY DAMAGE OR LOSS DURING SHIPMENT TO AND FROM THE FACTORY OR ITS DESIGNATED SERVICE FACILITY.

THIS GUARANTEE IS IN LIEU OF ALL OTHER GUARANTEES, EXPRESSED OR IMPLIED, AND OF ANY OTHER LIABILITIES ON THE MANUFACTURERS PART.

THE MANUFACTURER DOES NOT AUTHORISE ANYONE TO MAKE ANY GUARANTEE OR ASSUME ANY LIABILITY NOT STRICTLY IN ACCORDANCE WITH THE ABOVE.

THE MANUFACTURER RESERVES THE RIGHT TO MAKE CHANGES OR IMPROVEMENT IN THE DESIGN AND CONSTRUCTION OF THIS UNIT WITHOUT OBLIGATION TO MAKE SUCH CHANGES OR IMPROVEMENTS IN THE PURCHASER'S UNIT.

ANY DISPUTE ARISING FROM THIS WARRANTY SHALL BE SUBJECT TO THE LAWS OF ENGLAND.

### 7.2 What to do if a fault is found

---

If a fault develops in the unit, notify Advanced Music Systems or their nearest service facility giving full details of the difficulty. On receipt of this information, service or shipping instructions will be forwarded to you. No equipment should be returned under the warranty without prior consent from Advanced Music Systems or their Authorised Representative.

### 7.3 Shipping Information

---

Authorised returns should be prepaid and must be insured. All AMS products are packaged in specially designed containers for the best possible protection. If the unit is returned the original container should be used. If this is not possible, a new container can be obtained from Advanced Music Systems; please specify the model number when requesting a new container.

If the specially designed container is not used ensure that a suitable rigid container of adequate size is used, wrap the instrument in paper and surround it with a good thickness of shock absorbing material.

### 7.4 Claim for damage during transit

---

The instrument should be thoroughly inspected immediately upon delivery to the purchaser. If the instrument is damaged in any way a claim should be filed with the carrier immediately. A quotation to repair shipment damage can be obtained from Advanced Music Systems or their Certified Representative. Final claims and negotiations with the carrier must be completed by the customer.

### 7.5 Applications problems

---

Advanced Music Systems will be happy to answer all applications questions to enhance your use of this equipment. Please address all correspondence to:

Advanced Music Systems  
AMS Industries plc  
AMS Industries Park  
Billington Road  
Burnley  
Lancashire  
BB11 5ES  
England.

## 8 Quality Assurance and Service Policy

---

Over the years AMS products have gained an enviable reputation for their quality of design, performance and reliability, however, in the unlikely event that problems are encountered with this unit, please contact AMS Service at the appropriate address below or alternatively inform one of our world wide network of distributors who will be able to assist with any of your queries.

Advanced Music Systems	AMS / Calrec	AMS Service
AMS Industries plc	AMS Industries Inc	Audio Rents
AMS Industries Park	3827 Stone Way North	44, The Courtyard
Billington Road	P.O. Box 31864	Gloucester Road
Burnley	Seattle	London
Lancashire	WA 98103	NW1 8JD
England	USA	
BB11 5ES		

All AMS products are sold subject to our 'General Conditions of Sale' and the purchaser should note 'that the equipment is not being sold to him to meet his individual requirements and it is therefore the buyer's responsibility to ensure that the purposes and functions of the equipment meet his requirements prior to purchase.' However, we would non-the-less be grateful to receive any constructive criticism or ideas for additional features which you feel might enhance the usefulness of our product in the studio environment.

At AMS, we have an 'advanced module replacement policy' so that following telephone / fax diagnosis of your problem, equipment can be despatched as quickly as possible to reduce the product's 'down time' and ensure complete customer satisfaction with as little fuss as possible. All we ask is that you return the defective module within one month to assist our investigations and help minimize the likelihood of the problem re-occurring. Any charges levied for service is dependent on the warranty period of the product and the prompt return of modules affected.

The Quality Assurance Department  
 AMS Industries plc  
 Billington Road  
 Burnley  
 Lancashire  
 BB11 5ES  
 England.

## APPENDIX A

---

### Board Edge Connector Details

With component side facing and the edge connectors on the left the following applies:

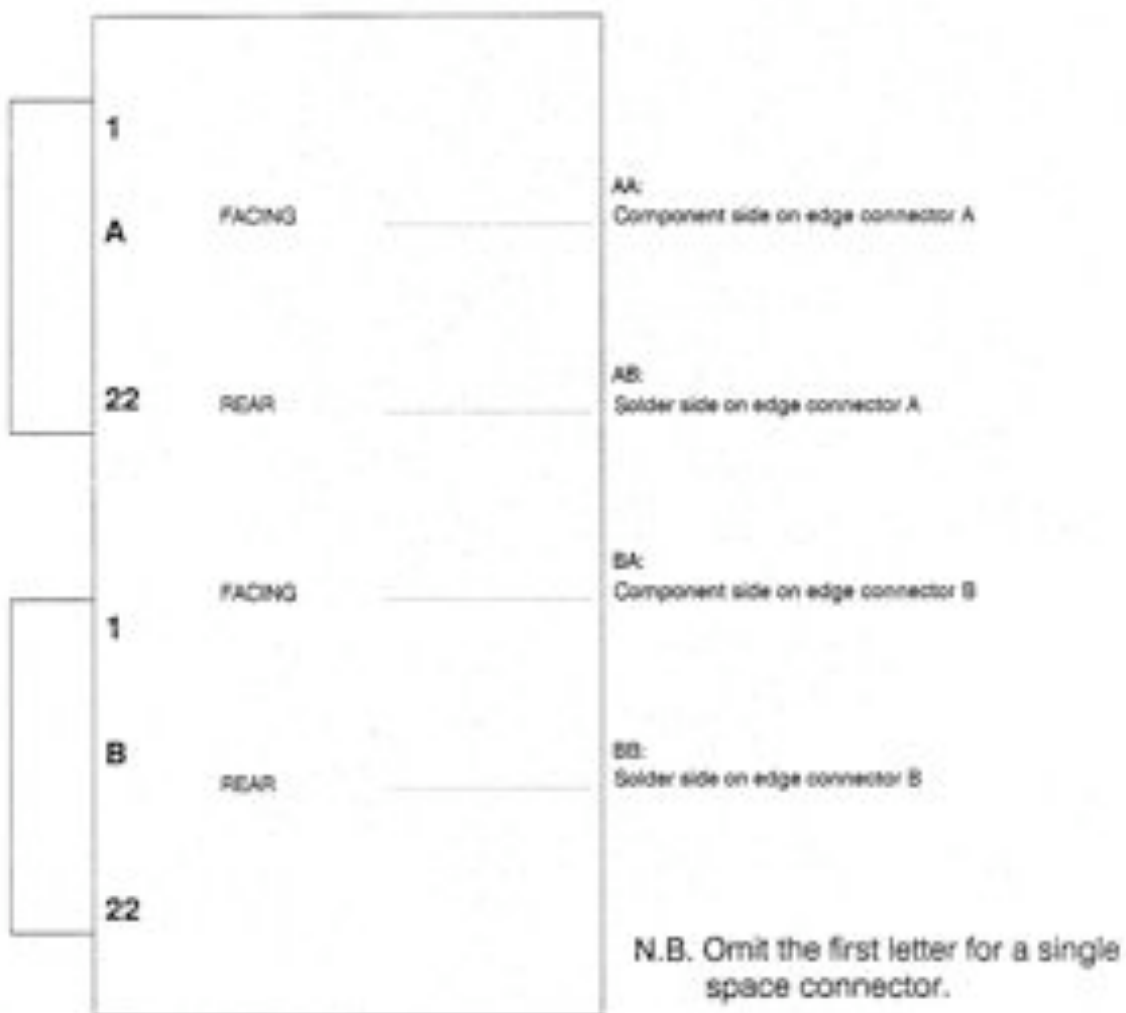

---

**APPENDIX B**

---

**Program Index - Revision 3.0 Software**

---

<i>Program</i>	<i>Title</i>	<i>Number</i>
1	Ambience	
2	Room	A1
3	Hall	C1
4	Plate	A1
5	Hall	B3
6	Chorus	
7	Echo	
8	Nonlin	2
9	Reverse	1

**Program 1 AMBIENCE**

---

This program is a very useful and flexible general purpose program with an effect somewhere between a hall and a plate. It is useful for increasing reverberation time on material with existing reverberation, or producing unobtrusive reverberation on dry material.

It differs from a hall in that dimensional elements are deliberately minimised, and differs from a plate in its lower colouration.

Pre-delay to 200ms is selectable and low and high frequency profiles can be modified.

Two special features of the program are that a setting of 9.9 on the decay controls gives an almost infinite decay time, and if the filters are set to their zero positions, the decay continues with all original harmonic information without air absorption simulation. This allows voices to be added into the sound one at a time to create a "choir" effect. This can also be described as a "freeze" setting and can be initiated by selecting "pot" on the decay control and rapidly turning from minimum (0.0) to maximum (9.9) settings as the sound you wish to "freeze" occurs.

(Caution: Since internal multiplying parameters are unity in this mode, after a long period of time in this condition - several minutes, or tens of minutes - the output dynamic range may limit due to very small DC offset voltages building up. The overflow LED will illuminate to show this. The condition is simply cleared by returning the decay setting to zero momentarily. In any case the effect is available for ample time for all useful purposes without problem).

---

**Program 2 ROOM A1**

---

This program is designed to replicate a "live" room with all the attendant colourations. Decay time should be kept short for most realism (to 1 or 2 seconds), and a high degree of high frequency damping sounds best (say -7,-8).

Low frequency equalisation is not provided for this program.

Colouration is made deliberately high to simulate standing waves in real rooms. All types of types of material are suitable for this program. Pre-delay to 300 milliseconds is selectable.

---

**Program 3 HALL C1**

---

This hall program has strong initial reflections thus defining the size of the hall distinctly, giving high presence, making it very useful for vocals, for example.

For "topping up" material already recorded in halls, a more neutral program such as Ambience is recommended, to avoid two possibly conflicting sets of early information.

Control of both high and low frequency profiles is provided as in program 1 above.

---

**Program 4 PLATE A1**

---

This is a program with high diffusion, similar to that produced by plate reverberators. Percussive sounds are rapidly smoothed with this program. Colouration is medium and decay even, as with standard plate reverberators.

Decay times of up to 5 seconds are useful for normal use, and above for special effects. Indicated decay times are accurate to about 5 seconds, but it should be noted that perceived delay time will depend greatly on the frequency spectrum of the input program material referred to the filter settings. Pre-delay of up to 300 ms is selectable.

Control of high and low frequency decay times is available

---

**Program 5 HALL B3**

---

This program is similar to Hall C1, but has lower energy initial reflections.

Pre-delay of up to 300ms is available.

Control of both high and low frequency equalisation is available.

### Program 6 CHORUS

---

This is a five voice program which is very useful for "filling out" voices and certain instruments.

The five voices are panned across the stereo image and are separated from each other by randomised delays operating on each voice. In addition, a basic separation is also selectable to bring the voices "closer" together or to "spread out" the image in time and space.

The program is controlled as follows:

The PREDELAY control affects the separation of the voices, as described above. The nudge controls increment in steps of 1ms instead of the normal 10ms because of the short delay nature of this program. The maximum value selectable is 50 ms which, over the five voices, gives a total spread of 250 ms.

At settings below about 6ms useful phasing/flanging/tunnelling effects are available. These effects are especially evident if the outputs are summed to mono.

The "depth" of the randomising and pitch changing effect is controlled by the DECAY control.

High frequency filtering of allvoices is available.

#### NOTE:

1) Phase cancellation and addition are very strong in this program by design, which can mean that slight adjustment of the input level control may be necessary dependent on program material to avoid overflow conditions.

2) This program is designed to be used mainly with voices. Program material with pure notes or large amounts of high frequency energy may introduce varying amounts of interference signal components due to discrete stepping of time increments as in other reverberation systems. This may be reduced by use of the high frequency filtering control.

In most cases however, very good effects can be obtained from this program as long as care is taken in choosing the relevant source material.

3) Since the control microprocessor is also responsible for refreshing the front panel display, slight disturbances in the intensity of the LEDs may be apparent at high settings of the decay control when the observer is close to the unit. This is not a fault condition.

---

**Program 7 ECHO**

---

This program provides two high quality, completely independent and programmable outputs from a single input. Control of decay is via PREDELAY, of feedback level (regeneration) via the DECAY control and high and low filtering can be selected in the decay path in the normal way.

To select which output to program, the 'A' or 'B' keys should be depressed as appropriate. The program title will reflect this selection, displaying ECHO A or ECHO B accordingly.

To allow the greatest flexibility in generating effects with this program, the maximum delays selectable on each output have been set differently - either 650ms / 150ms or 1.2s / 400ms.

This program can be used to great effect for double / triple tracking, longer delays simulate tape echo, and very long delays with high degree of feedback allow a musician to effectively "play along" with himself by laying a new bar on top of previous slowly decaying bars to build up a very full sound. Since the regeneration is accomplished in the digital domain, a very clean effect is generated.

Both high and low frequency profiles can be modified.

---

**Program 8 NONLIN 2**

---

This is an unusual program for special effects or loudness enhancement, in which the sound decays only very slightly for a period of time (set by the decay control), and then dies away very rapidly. It is especially useful on drums, and at small settings of decay produces a very good room effect. The decay values are not calibrated in this mode, but values may be used for reference. Unlike NONLIN 1, the output is in stereo, and filtering at high frequencies is available.

---

**Program 9 REVERSE 1**

---

This is another special effects program with two outputs of separate character. One output has discrete reflections (output 2), the other has more diffused character (output 1). Either output may be used but it should be noted that this feature is designed to offer maximum flexibility, and it is not intended that both variations are used together as a stereo pair.

Dependent on the setting of the decay control, the reverberating sound builds up for a period of time then suddenly stops - the reverse of natural reverberation. Again decay settings are not calibrated but may be used for reference.

A predelay is selectable before the start of the reverb build up.

## APPENDIX C

---

### High and Low Frequency Decay Characteristics

---

High and low frequency profiles may, for many programs, be modified as specified below. These figures apply to the final, reverberant phase of the decay of each program, but early reflections are also affected in certain programs, so the figures should be used as a guide only. The final setting should be selected by ear.

#### Nominal high frequency decay control characteristics:

Setting	Half decay time frequency
0	18kHz (flat)
-1	15kHz
-2	10kHz
-3	8kHz
-4	6.5kHz
-5	5kHz
-6	3.5kHz
-7	2kHz
-8	1.5kHz
-9	1kHz

#### Low frequency decay control characteristics:

The low frequency filter control affects the decay time of the reverberant phase of the programs at a frequency of 350Hz, varying nominally from a quarter of the indicated time at a setting of -9, to four times at +9. Program material content varies the subjective effect of this control considerably; again it is best set by ear.

## APPENDIX D

---

### RMX 16 REMOTE OPERATING INSTRUCTIONS

---

#### SWITCH ON

If the unit is switched on without being connected to the RMX 16 (or the RMX 16 is not switched on) then the following message will be displayed:

CONNECT RMX 16 !

The REMOTE should then be connected to the mainframe (or the mainframe should be switched on).

#### THE KEYS

##### KEY OPERATION

Looking at the remote you will find that there are two keys for entry of each variable parameter. For each parameter one key has the arrow pointing upwards, indicating that the nudge will increase the value, and the other has the arrow pointing downwards indicating that the nudge will decrease the value of the parameter selected.

When a key is first selected the existing parameter(s) are displayed unchanged. Further pressing of the key will then increment or decrement the parameter depending on which of the two keys is selected.

Nudging can be accomplished continuously by simply holding the relevant key down.

##### STATUS

Once the Remote has been connected to the mainframe switch on both units. If at this point the remote is not displaying sensible data press the STATUS key (you may have to do this a number of times if the remote was switched on before the mainframe). On pressing status the name of the program, the decay time and the filter settings for the temporary store will be displayed.

for example: `PLATE A1 2.0 0.5`

##### ID

On pressing the ID key the current software version installed in the mainframe will be displayed.

for example: `BMX 16-REV 1.6`

**SAVE**

On pressing the SAVE key the store location currently being addressed will be displayed.

for example: SAVE STORE NO = 10

To save the data (at present in the temporary store) in store location 19 simply increment until the display reads:

SAVE STORE NO = 19

then press ENTER.

**RECALL**

On pressing the RECALL key the store location currently being addressed will be displayed.

for example: RECALL STR.NO = 19

To actually recall the data stored in store 19 the ENTER key must be pressed.

**CLEAR**

Pressing the CLEAR key followed by the ENTER key will initiate the clear cycle start: the display will read:

CLR CYCLE START

To actually start the clear cycle a further two ENTER key strokes are required. On pressing the ENTER key for the second time the display will read :

CLR ALL? YES = ENT

if the enter key is pressed again the display will read:

Y = ENT, ABORT = CLR

if the enter key is pressed again ALL of the store locations from 10 to 99 will be cleared and the display will read:

STORES CLEARED

The currently accessed store location will be 1.

As indicated in the last message before the stores are cleared, pressing the CLEAR key will stop the clear cycle. If the CLEAR key is pressed instead of the enter key the display will read:

CLEAR CANCELLED

Once clear has been cancelled pressing the ENTER key alone will have no effect.

## STORE

On first pressing the STORE key the display will change to:

for example: NEW STORE NO. = 10

A further pressing of one of the STORE keys will either increment or decrement the new store value depending on which of the STORE keys was operated. If the "up arrow" key was pressed once the display would read:

NEW STORE NO. = 11

## PROG

On first pressing the PROG key the display will change to:

for example: PROG. 1:PLATE A1

A further pressing of one of the PROG keys will either increment or decrement the program value depending on which of the PROG keys was operated. In this case if the "up arrow" key was pressed once the display would now read:

PROG. 2:PLATE B1

## PREDEL

On first pressing the PREDEL key the display will change to:

for example: PREDELAY = 55ms

A further pressing of one of the PREDEL keys will either increment or decrement the pre-delay value depending on which of the PREDEL keys was operated. If the "up arrow" key was pressed once the display would read:

PREDELAY = 65ms

Note that the pre-delay is incremented in 10ms steps.

## LO FILT

On first pressing the LO FILT key the display will change to:

for example: LO FILTER = +2

A further pressing of one of the LO FILT keys will either increment or decrement the low filter value depending on which of the LO FILT keys was operated. If the "up arrow" key was pressed once the display would read:

LO FILTER = +3

If, because of the program selected, there is no filter available then the following will be displayed:

LO FILTER = NONE

## HI FILT

On first pressing the HI FILT key the display will change to:

for example: HI FILTER = -2

A further pressing of one of the HI FILT keys will either increment or decrement the high filter value depending on which of the HI FILT keys was operated. If the "up arrow" key was pressed once the display would read:

HI FILTER = -1

If, because of the program selected, there is no high filter available then the following will be displayed:

HI FILTER = NONE

## DECAY

On first pressing the DECAY key the display will change to:

for example: DECAY TIME = 2.0s

A further pressing of one of the DECAY keys will either increment or decrement the decay time value depending on which of the DECAY keys was operated. If the "up arrow" was pressed once the display would read:

DECAY TIME = 2.1s

Note that the decay time is incremented in 0.1s steps.

#### BATTERY LIFE

DO NOT USE PRIMARY CELLS (alkaline or any other non-rechargeable cell) WITHIN THE REMOTE UNIT WITHOUT PRIOR CONSULTATION WITH AMS OR THEIR AUTHORISED DISTRIBUTOR. DAMAGE TO THE UNIT WILL BE SEVERE IF PRIMARY CELLS ARE PUT ON CHARGE.

If the REMOTE is subjected to very heavy usage the trickle charge from the RMX16 mainframe may not be sufficient to maintain the cells in a fully charged state. If it is felt that the REMOTE is likely to be used under such circumstances a charger is available from AMS, or their Authorised Distributor, which will charge the cells overnight.

#### BATTERY LOW

When battery charge is running low a BATTERY LOW warning message will be given on the display. This message is generated on every tenth keystroke, it does not affect the data storage or handling.

THE BATTERY LOW MESSAGE MUST NOT BE IGNORED SINCE LOSS OF DATA WILL OCCUR IF THE BATTERY VOLTAGE IS ALLOWED TO DROP TOO FAR.

If the BATTERY LOW message is displayed either leave the REMOTE connected to the mainframe, but switched off, for 48 hours (the mainframe must be powered continuously during this period) or preferably put the unit on charge (using the DMX 1048 battery charger) overnight.

## APPENDIX E

---

### RMX16 REMOTE CONTROL BARCODE INSTRUCTIONS

---

#### Loading and Transferring Reverberation Programs using the Bar Code Wand

##### *1 The Bar Code Wand*

Purchase of the bar code wand option allows you to expand your programming capabilities by providing three "Soft Program" stores within the Remote Terminal and an additional three "Soft Program" stores within the RMX16 unit. These "Softprogs" must not be confused with the 99 selectable store locations that already exist in the Remote Terminal and RMX16 (Mainframe) unit.

The "Softprog" stores can only be accessed by using the bar code wand. This gives a simple method of entry and a convenient method of distribution of new programming material.

Program storage is divided as follows:

**Programs 1 - 9** inclusive are the original nine programs already contained within the EPROMS of your unit. These programs cannot be overwritten.

**Programs 10 - 12** inclusive are defined as MAINFRAME soft programs.

**Programs 31 - 33** inclusive are the REMOTE soft programs.

Depending upon the soft program number entered, the programs can be loaded either into the REMOTE or directly into the MAINFRAME (so long as the MAINFRAME is attached to the REMOTE). Also by using the barcode wand, soft programs can be transferred from the REMOTE to the MAINFRAME and vice versa.

##### *2 Loading a program direct from the bar code wand to either the REMOTE or the MAINFRAME*

**NOTE:** All input instructions are to be made via the bar code wand using the command and numeric sections at the top of the bar code sheet. If at any time you wish to resume normal operations, simply enter "ABORT" using the bar code wand. This will return you to the standard remote functions i.e. MAINFRAME program manipulation.

To load a program directly from the bar code sheets into the MAINFRAME or the REMOTE, enter "LOAD PROGRAM" into the REMOTE using the bar code wand. The REMOTE display will now read:

SOFT LOC No?

At which point you must enter the location number using the tablet on the bar code sheet. Once the "soft program store location" has been entered the display will read:

**READ PROGRAM**

- if the program store is available and has not been previously written to.

**ERASE programme ?**

- if the soft store location already has a program within it. "NO" will result in a repeat of the "SOFT LOC No?" message,

and "YES" will result in the "READ PROGRAM" message being displayed.

"programme" is the mnemonic for the actual program title (8 characters).

**ERROR!**

- if the store location is not available, e.g. less than 1 or greater than 33.

Once "READ PROGRAM" is displayed the actual program can then be entered.

The lines can be entered in any sequence, except the last line which should be entered after all the other lines have been entered. As each line of the program is entered the data is checked and verified to ensure that no part of a line is missing. If the line was entered successfully a "beep" will be heard, otherwise the line must be re-entered.

Once the last line has been entered the whole program is checked and if any lines are missing the REMOTE will ask for these lines to be re-entered:

**READ LINE 16**

etc....

Once the program has loaded correctly the receiving unit will display the full STATUS information of the program that has just been loaded, for example:



The REMOTE will then be ready for the next data entry.

If at any time you wish to stop entry of a program then simply enter "ABORT" using the barcode wand. This will return you to the standard REMOTE functions i.e. MAINFRAME program manipulation.

### 3 Transferring programs from the REMOTE to the MAINFRAME and vice versa.

These two operations are virtually identical; they differ only in so much as one transfers data from the MAINFRAME to the REMOTE and the other transfers data from the REMOTE to the MAINFRAME. In either case once the option has been selected the prompt is:

FROM LOC?

After entering the soft program number to be transferred the display will read:

TO LOC?

- If the program number is acceptable and a program is present.

NO PROGRAM !

- If the program number is acceptable, but there is no program present. "CLEAR" may now be entered to return to the "FROM LOC?" prompt.

ERROR

- If the program number is not acceptable. "CLEAR" may now be entered to return to the "FROM LOC?" position.

After entry of the soft program destination the display will read:

SENDING

- If the program is being transferred from the REMOTE to the MAINFRAME.

RECEIVING

- If the program is being transferred from the MAINFRAME to the REMOTE.

ERASE program ?

- If the location to be written to already contains data. "NO" will result in the "TO LOC?" message being re-displayed. "YES" will result in the old data being overwritten and the "SENDING" or "RECEIVING" message being displayed. "program" is a mnemonic for the actual program title (8 characters).

ERROR

- If the location given in response to the "TO LOC?" question does not exist.

---

**PROGRAM INDEX FOR BARCODE SOFTWARE**

---

<i>Delay</i>	44
<i>Freeze</i>	44
<i>Half A1</i>	45
<i>Image P1</i>	45
<i>Nonlin 1</i>	45
<i>Plate B1</i>	46
<i>Reverse 2</i>	46
<i>Room A0</i>	46
<i>Room B1</i>	47

## DELAY

---

This program gives very high quality delays of up to 810 milliseconds or 1.63 seconds, depending upon the version of RMX 16 being used. The delay required is set by selection of pre-delay. The decay time control then acts as a feedback control, zero decay time giving a single repeat echo whilst above zero regenerative echo effects may be obtained. When used for this function the decay time control is not calibrated. Since the feedback is achieved digitally, no degradation of the repeated sound occurs, and the effect is quite remarkable for its clarity.

This delay appears on output 2 only. Output 1 is 'straight through' the Analog-to-Digital-and-back-again chain. (For 2 channel operation, ECHO splits the available delay time between the channels, with independent control over delay and feedback).

Short delays may be used for 'automatic double tracking' or 'doubling' (up to about 40-50 mS), longer delays to simulate tape echo, and very long delays coupled with a high degree of feedback allow a musician to effectively 'play along' with himself by laying a new bar on top of previous slowly decaying bars to build up a very full sound.

## FREEZE

---

It has always been possible to select an infinite decay to which further input may be added on the RMX16. This was achieved by setting the AMBIENCE program to maximum decay with high and low filters set flat to zero. This feature has been made easier to control with the FREEZE program.

The program is controlled as follows:

The only control that is necessary is the decay control. The following settings only are effective:

- 0.0 Clear - this setting allows the 'frozen' setting to be released
- 0.1 Freeze/add - in this position, the program will accept and freeze incoming audio
- 0.2 Freeze/mute input - in this position the algorithm continues at infinite decay time, but gates out incoming audio.

Although the above may sound complicated, in practice it is a very easy operation using the nudge button on decay. By using first and second fingers to switch between the three values - adding audio when ready at 0.1 and gating out when the required amount of extra signal has been introduced, very concise control of the effect is available.

(Note: all settings above 0.2 give the freeze/mute condition - thus the use of the decay pot is not of much value with this program.)

**HALL A1**

---

This program has a similar history to ROOM A0. Used by some to great effect, especially on vocals - it was replaced to allow greater smoothness in decay, but this feature was liked by some.

Low frequency control of decay profile is not available on this program. Predelay to 300ms can be selected.

**NONLIN 1**

---

This program is for special effects or loudness enhancement, in which the sound does not decay for the first period of time set by the decay control, then very rapidly dies away. The decay values are not calibrated in this mode, but values may be used for reference.

A predelay before the reverberation begins is also selectable.

The program has two outputs - one having discrete reflections (2), the other having a more diffused character (1). Either output may be used at short decay times for multiplying percussive sounds like handclaps - the smoother program at short decay times for a certain type of room simulation.

**IMAGE P1**

---

This program is the first of a series of IMAGE programs which are designed for very special effect. IMAGE P1 is a program similar to the NONLIN series, except that the reverberation produced pans between the stereo outputs as it proceeds. The length of time of the effect is selectable by the decay controls between a few milliseconds and about 0.6 seconds and can produce some very startling image effects which obviously have no equivalent in natural environments.

Control of the brightness of this program is achieved via the HI FILTER control.

If the stereo outputs of this program are summed to mono, an effect similar to NONLIN will be obtained.

**PLATE B1**

---

This is a program with high diffusion, similar to that produced by plate reverberators. Percussive sounds are rapidly smoothed with this program. Colouration is medium and decay even as with standard plate reverberators.

Decay times of up to five seconds are useful for normal use, and above for special effects. Indicated decay times are accurate to about 5 seconds, but it should be noted that perceived decay time will depend greatly on the frequency spectrum of the input program material referred to the filter settings.

Predelay of up to 300 milliseconds is selectable.

Control of high and low frequency decay times is available.

**REVERSE 2**

---

This is another special effects program with two outputs of separate character. One output has discrete reflections (output 2), the other has a more diffused character (output 1). Either output may be used but it should be noted that this feature is designed to offer maximum flexibility, and it is not intended that both variations are used together as a stereo pair.

Dependent on the setting of the decay control, the reverberating sound builds up for a period of time and then suddenly stops - the reverse of natural reverberation. Again, decay settings are not calibrated but may be used for reference.

A predelay is selectable before the start of the reverb build-up.

Unlike REVERSE 1, the output is in stereo and filtering at high frequencies is available.

**ROOM A0**

---

This is the original version of ROOM A1 - shipped with very early RMX 16 units. The program was later modified to restrain the very top end of the response, which could be a little difficult with certain program material. However, a number of well respected users had utilised this program to great effect and have asked to be given access to it once more.

Controls are as for ROOM A1.

**ROOM B1**

---

This room has constant diffusion density with time, and utilises a completely different algorithm to ROOM A1. Maximum decay time is of the order of 700 mS, and because of the constant diffusion rate the impression of size of room is altered by the DECAY control.

This program is very useful when very short decay times are required, and also for drama dubbing where fine control is required over the perceived dimensions of particular environments.

High frequency control is provided to simulate the amount of HF damping in the room.

