

GENELEC®

A C T I V E M O N I T O R I N G

Genelec 1092A and 1094A Active Subwoofer Systems

Data sheet



Genelec Active Subwoofer Systems



APPLICATIONS

Broadcast Monitoring

Surround Sound

Monitoring

TV Control Rooms

Video Post Production

Project / Home Studios

Digital Workstations

SYSTEMS

Genelec's active subwoofers are powerful low frequency loudspeakers, incorporating all the amplifier and crossover electronics needed to combine them with other loudspeakers amplifiers and signal sources.

The 1094A is a powerful system, capable of reproducing frequencies in the range 29 - 80 Hz (± 2.5 dB). The 1092A is a compact system that will reproduce frequencies of 33 - 80 Hz (± 2.5 dB).

The amplifier unit integrated into the cabinet contains active crossover filters, driver overload protection circuits and a power amplifier. The cabinet is made from MDF with rounded corners and hard-wearing textured black surface. The crossover has 3 signal channels (L/C/R) input and output channels and a discrete subwoofer signal (.1) input, providing great flexibility and allowing easy

connection to existing monitor systems, whether one, two or three channel, or to proprietary surround sound decoders.

The unit has adjustable sensitivity and a bass roll-off and phase matching control to tailor the response of the subwoofer to its environment.

INTEGRATED CONSTRUCTION

The combination of the cabinet and amplifier in one unit results in a robust and simple system.

The amplifier is mounted on pivoting vibration absorbers, which prevent damage to the electronics and ensures easy access and maintenance of the amplifier.

The cabinet is made from MDF with rounded corners and hard-wearing textured black surface. The drivers are concealed inside an efficiency boosting cavity, which also protects them from physical damage.

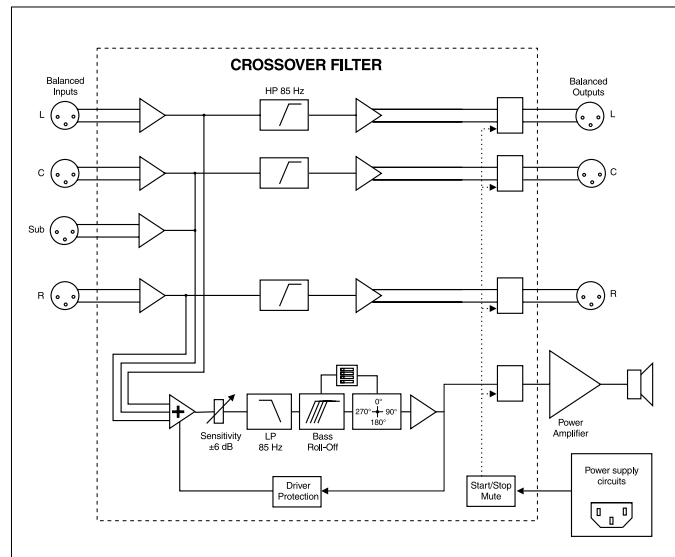

Block diagram, showing active crossover filters, power amplifiers and driver units.

SPEAKER CONFIGURATIONS AND POSITIONING

Both the 1094A and 1092A may be used in conjunction with other Genelec monitors to extend the low frequency response and SPL performance. It is advised that they be used with models 1029A through to 1037A. Due to the versatile crossover filters, stereo, analogue matrix surround and digital 5.1 channel surround systems may be easily configured. Some recommended configurations are shown on the opposite page.

By positioning the subwoofer close to a wall, its radiation efficiency can be maximized and some adverse room effects minimised. In

this way, the effective subwoofer output is doubled and avoids possible interference dips in the frequency response.

Accordingly, the Genelec subwoofers have been designed so that they may be flush mounted whilst allow access to the amplifier connections and controls. Alternatively, due to their omnidirectional dispersion, the same result may be achieved by positioning the subwoofers free standing with the ports and the amplifier facing the wall.

The inclusion of a phase correction switch in the crossover allows for the subwoofer to be freely placed away from the main monitors, without resulting in phase cancellation.



1094A employed in a stereo system (refer to recommended setups on opposite page)



1092A employed in an L/C/R Surround sound system

1094A



AMPLIFIER

The amplifier produces 400 W of short term RMS power, with very low THD and IM distortion. It is mounted on a large, thick aluminium plate, which provides excellent heat dissipation. Driver overload protection and power-on signal muting is included in the amplifier circuitry. The amplifier also incorporates a soft start power supply, thermal overload and short circuit protection.

The 1094A includes a clip LED on the amplifier panel, which lights if the amplifier is overloaded.

DRIVERS

The 1094A has one 385 mm (15") cone driver, capable of producing very high SPLs. The driver is housed in a 110 liters vented cabinet. The drivers are specially front loaded to improve both the passband efficiency and stopband rejection.

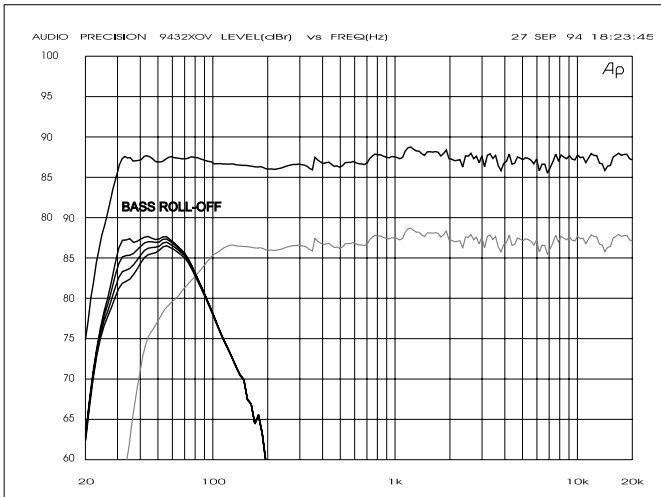

The leftmost curves show the 1094A free field frequency response at different bass roll-off settings. The right hand curve is the high passed 1032A free field frequency response. The upper curve shows the total system free field frequency response.

CROSSOVER FILTERS

The active crossover contained in the amplifier unit splits the input signals into low and high frequency components, accurately dividing the input signal between the subwoofer and the main speakers. The low pass section has ± 6 dB adjustable sensitivity, to allow easy level matching with the various main speakers. The three high pass sections have 0 dB passband gain.

To provide a flat bass response in many different acoustic environments, a calibrated 'bass roll-off' switch is included, which makes adjustments to the subwoofer response in three -2 dB steps. A

phase matching switch in the crossover allows compensation for the delays which occur if the subwoofer is placed away from the main speakers or for other speaker systems phase behavior. Four settings are provided between 0° and -270° . Balanced XLR connectors are used for the system inputs and outputs.

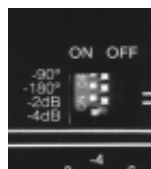

Bass roll-off (0,-2,-4,-6 dB) and phase (0° , -90° , -180° , -270°) switching controls

1092A

DRIVERS

The 1092A uses two 210mm (8") cone drivers with large magnets and large displacement capability (18 mm peak-to-peak). These properties allow the reproduction of low frequencies at high levels. The drivers are housed in a 55 liters vented cabinet. The drivers are specially front loaded to improve both passband efficiency. This also improves stopband rejection.



AMPLIFIER

The amplifier produces 180 W of short term RMS power, with very low THD and IM distortion.

The amplifier includes circuitry for driver overload protection ensuring the long term reliability of the drivers. The unit also contains a muting circuit, which disconnects the amplifier and filter outputs when the mains power is switched on and off, to prevent pops and clicks. Thermal overload protection is also provided.

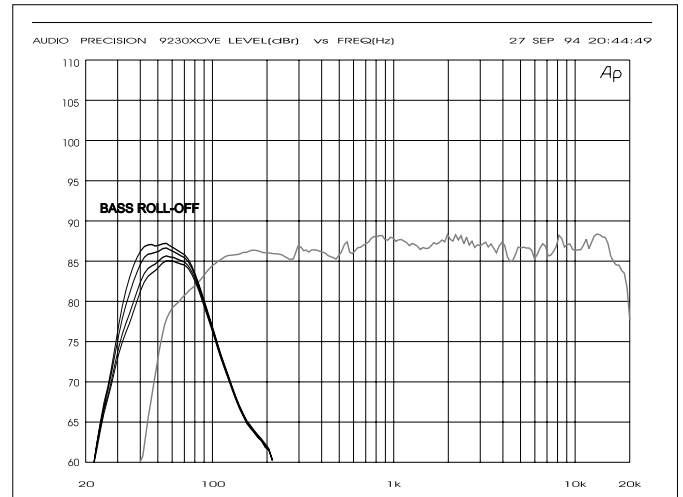

The leftmost curves show the 1092A free field frequency response at different bass roll-off settings. The right hand curve is the high passed 1030A free field frequency response.

Recommended setup configurations

Main Monitor	Stereo system	L/C/R Surround Sound System
1029A / 1030A	1 x 1092A	1 x 1092A
1031A	1 x 1092A	1 x 1094A or 2 x 1092A
1032A / S30C / 1037B	1 x 1094A	1 x 1094A

Options



Opt-03
Magnetic shielding
Order Code
1092: 1092-403
1094: 1094-403

GENELEC®

A C T I V E M O N I T O R I N G

SYSTEM

SPECIFICATIONS

	1094A	1092A
Free field frequency response of system (± 2.5 dB):	29 - 80 Hz	33 - 80 Hz
Maximum short term sine wave acoustic output in half space, averaged from 35 Hz to 85 Hz @ 1m:	≥ 120 dB SPL	≥ 115 dB SPL
Self generated noise level in free field @ 1m on axis (A-weighted)	≤ 10 dB	≤ 10 dB
Harmonic distortion at 100 dB SPL @ 1m on axis in half space (30...100 Hz):	$< 3\%$	$< 4\%$
Drivers:	385 mm (15")	2 x 210 mm (2 x 8")
Weight:	50 kg (110 lb)	30 kg (66 lb)
Dimensions:	Height	739 mm (29 1/16")
	Width	468 mm (18 7/16")
	Depth	620 mm (24 7/16")

CROSSOVER SECTION

Both Models

Subsonic filter (18 dB/octave) below:	29 Hz	33 Hz
Crossover frequency, (sub/main monitors)		85 Hz
Crossover frequency, (sub input channel)	Full band/85 Hz	
Crossover acoustical slope	28 dB/octave	
Lowpass:	12 dB/octave	
Highpass:	≥ 50 dB	
Midband rejection, freq. ≥ 400 Hz:	≥ 50 dB	
Bass roll-off control operating range in 2 dB steps:	from 0 to -6 dB @ 33 Hz	
Phase matching control in 90° steps:	from 0° to -270° @ 85 Hz	

AMPLIFIER SECTION

1094A 1092A

Short term amplifier output power: (Long term output power is limited by driver unit protection circuitry.)	400 W (8 Ohm)	180 W (4 Ohm)
Amplifier system distortion at nominal output:		
THD	$\leq 0.08\%$	$\leq 0.08\%$
SMPTE-IM	$\leq 0.08\%$	$\leq 0.08\%$
CCIF-IM	$\leq 0.08\%$	$\leq 0.08\%$
DIM 100	$\leq 0.08\%$	$\leq 0.08\%$
Signal to Noise ratio, referred to full output:	≥ 100 dB	≥ 100 dB
Mains voltage:	100/200 or 115/230V	
Voltage operating range:	$\pm 10\%$	
Power consumption (average):		
Idle	60 VA	50 VA
Full output	650 VA	300 VA

INPUT SECTION

Both Models

Input connectors: XLR female.	pin 1: gnd pin 2: + pin 3: -
Input impedance:	10 kOhm balanced
Input level for 100 dB SPL output @ 1m:	variable from +6 to -6 dBu

OUTPUT SECTION

Both Models

Output connectors: XLR male.	pin 1: gnd pin 2: + pin 3: -
Output impedance:	100 Ohm balanced, active floating
Gain:	0 dB

GENELEC®

Genelec Oy, Olvitie 5
FIN-74100 IISALMI, FINLAND
Phone: +358 17 83 881
Telefax: +358 17 812 267
Email: genelec@genelec.com
Web: http://www.genelec.com

Genelec Inc, 7 Tech Circle
Natick, MA 01760, USA
Phone: +1 508 652 0900
Fax: +1 508 652 0909
Email: genelec.usa@genelec.com



Data Sheet No. BBA9294001a
COPYRIGHT GENELEC OY 11/2000
All data subject to change without prior notice